

# **Network Protector Instruction Manual**

**Type 313NP**

**800 to 3500 Amperes**

** Richards**

**MANUFACTURING COMPANY, SALES, INC.  
517 LYONS AVENUE, IRVINGTON, NJ 07111  
Phone 973-371-1771 Fax 973-371-9538**

**IM 1223-001B**



## **DISCLAIMER OF WARRANTIES AND LIMITATION OF LIABILITY**

All equipment or component parts manufactured or distributed by Richards Mfg. Co., Sales Inc. are expressly warranted by Richards to be free from defect in workmanship or material when subjected to normal and proper use. Said warranty shall be for a period of one (1) year from the date of installation of such equipment not to exceed eighteen (18) months from the date of shipment of such equipment. Notice of any claim arising out of this warranty shall be made in writing within the warranty period. Richards' sole liability and buyer's sole remedy under this warranty shall be limited to the repair or replacement, FOB factory, of any equipment or part determined to be defective in either material or workmanship. This warranty does not apply to any equipment, part or component requiring repair or replacement due to improper use or when determined to have been subjected to abnormal operating conditions or in the event of buyer's failure to follow normal maintenance procedures.

No warranty or guarantee expressed or implied, including any warranty or representation as to the design, operation, merchantability or fitness for any purpose is made other than those expressly set forth above which are made in lieu of any and all warranties or guarantees. Richards Mfg. Co. shall not be liable for any loss or damage, directly or indirectly, arising out of the use of equipment or parts (including software) or for any consequential damages, including but not limited to, any claims for buyer's lost profits or for any claim or demand against the buyer by a third party.

Richards Mfg. Co. assumes no responsibility for any damage or loss resulting from the use of this manual. Information in this document is subject to change without notice.

## **SAFETY INFORMATION**

This manual is intended for use by qualified individuals responsible for the installation, maintenance and operation of network protectors. Potentially unsafe conditions exist when installing, maintaining or operating network protectors.

All applicable safety procedures should be adhered to when installing, maintaining, or operating network protectors.

Only qualified electrical personnel should be permitted to work on 313NP Network Protectors.

De-energized and rack out the network protector mechanism before any maintenance procedure.

Never defeat safety interlocks on the network protector.

Never energize a partially assembled network protector.

Use extreme caution when installing or working on an energized protector.

Use insulated tools and gloves when working on energized network protectors.

Perform all appropriate electrical tests before any installation or operation of the network protectors.

## **WARNING**

Before unpacking, installing, servicing, or operating 313NP network protectors read this manual thoroughly.

For additional information, contact Richards Mfg. Co. directly.

For application information, consult Richards Mfg. Co. or see appropriate ANSI Standards.

Do not operate 313NP network protectors under load except in appropriate enclosures.

The Richards 313NP Network Protectors are designed for secondary network application at 125/216 volt, 277/480 volt and 347/600 volt wye connected systems. Do not exceed design ratings.

# Submersible Transformer Mounted

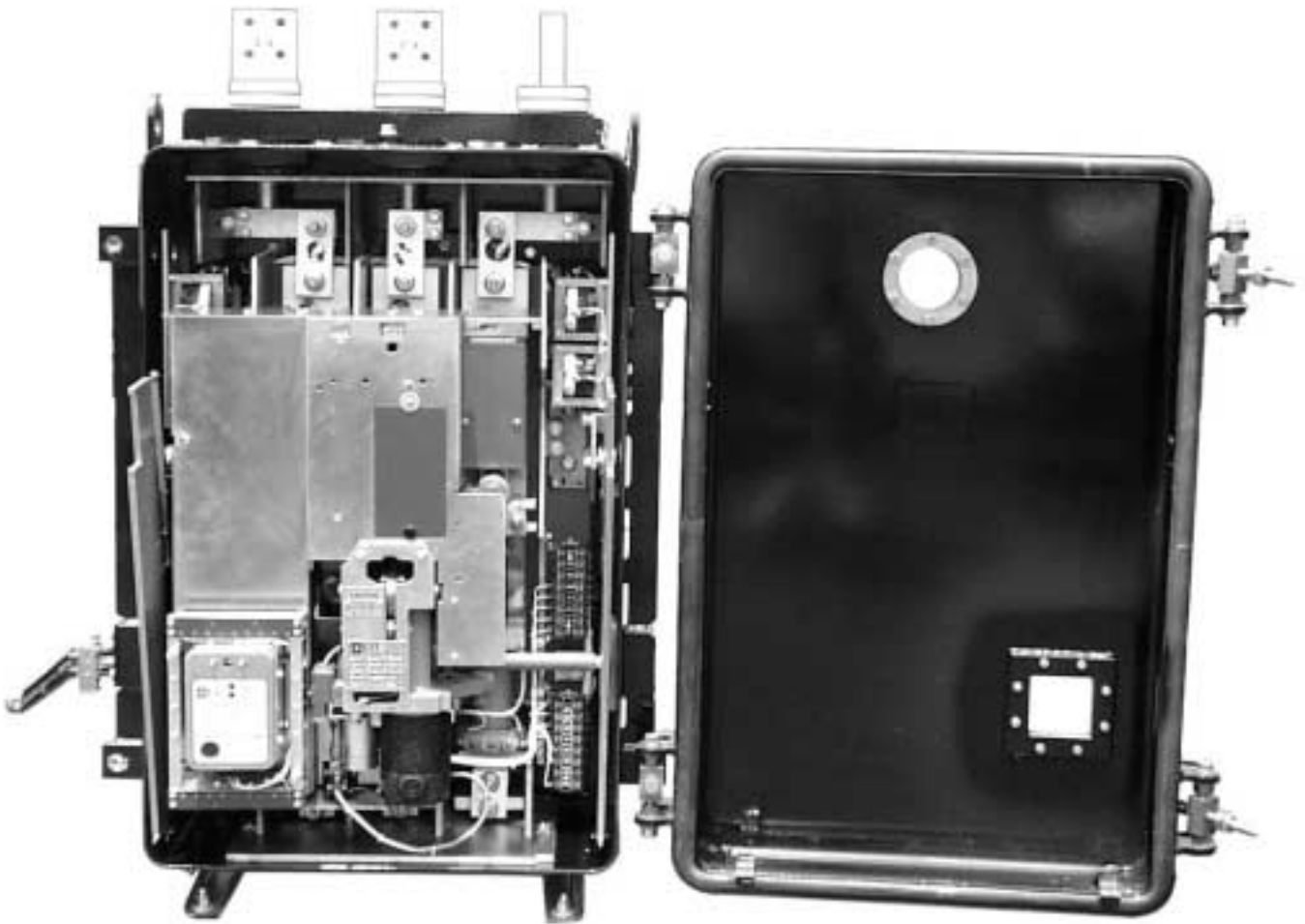

# Non-Submersible Transformer Mounted



## **TABLE OF CONTENTS**

	<b><u>PAGE</u></b>
<b>I. OVERVIEW</b>	
A. Introduction	1
B. 313NP Ratings	1
C. 313NP Housings	1
D. The 313NP Mechanism	3
<b>II. INSTALLATION</b>	
A. Receipt Of The 313NP	4
B. Preliminary Testing	4
C. Mounting the 313NP – Mechanical Connection to Transformer	
1. Wall Mounted Protectors	5
2. Transformer Mounted Protectors	5
D. Mounting the 313NP – Testing and Electrical Connection to Transformer	5
E. Energizing the Feeder	6
F. Checking a Submersible Housing for Water-Tightness	6
<b>III. 313NP DESIGN</b>	
A. The 313NP Circuit Breaker	
1. 313NP Units Up To 1875 Amperes	7
2. 313NP Units From 2000 to 3500 Amperes	9
B. The 313NP Mechanism	12
C. The Operating Handle	13
D. The Relay Panel and Auxiliaries	14
E. The Closing Motor	14
F. The Shunt Trip Assembly	14
G. Motor Circuit Control	15
I. Position Indicator and Operations Counter	15
<b>IV. 313NP HOUSINGS</b>	
A. Submersible Housings	16
B. Ventilated Housings	17
<b>V. MAINTENANCE</b>	
A. Mechanical Inspection	
1. The Circuit Breaker Unit	18
2. Relay and Mechanism Frame	18
3. The Housing	19

<b>B. Contacts 800 through 1875 Amperes</b>	
1. Flexible Contacts	19
2. Main Contacts	19
3. Arcing Contacts and Arc Chutes	19
<b>C. Contacts 2000 through 3500 Amperes</b>	
1. Blades	20
2. Arcing Contacts	20
<b>D. Fuses</b>	20
<b>E. Fiberglass Barriers</b>	20
<b>F. Current Transformers</b>	20
<b>G. Miscellaneous</b>	
1. Motor Control Relay Switch	21
2. Dashpot	21
3. Motor Brushes	21
4. Shunt Trip and Motor Closing Units	21
5. Motor Cutoff Switch	22
6. Auxiliary Switch	22
7. Auxiliary Relay	22
<b>H. Submersible Housing</b>	
1. Leak Testing	22
2. Gaskets	
a. Materials	23
b. Replacement of Cover Gasket	23
c. Adjustment of Door Gasket	24
3. Centering the Cover in the Housing	24
4. The Operating Handle	25
<b>I. Non Submersible Housings</b>	27

## **VI. ADJUSTMENTS**

<b>A. Circuit Breaker, 800 through 1875 Ampere Units</b>	28
<b>B. Circuit Breaker, 2000 through 3500 Ampere Units</b>	28
<b>C. Adjusting the Operating Mechanism</b>	30
<b>D. Adjusting the Housing</b>	31

## **VII. DIAGRAMS**

<b>A. Wiring Diagram, 125/216 Volt Protectors</b>	32
<b>B. Schematic Diagram, 125/216 Volt Protectors</b>	33
<b>C. Wiring Diagram, 277/480 Volt Protectors</b>	34
<b>D. Schematic Diagram, 277/480 Volt Protectors</b>	35

## I. OVERVIEW

### A. Introduction

The Richards 313NP Network Protector consists of a circuit breaker, a motor operated mechanism, and an ETI Microprocessor Network Protector Relay that combines the functions of a network master relay, and a network-phasing relay. The ETI MNPR™ provides all modes of operation, including sensitive, insensitive, time delay, instant, watt-var, and inverse watt-var.

The circuit breaker has contacts fashioned from silver tungsten. In addition, the breaker has metal arcing contacts to protect the primary and secondary contacts from the initial arc generated when the protector is closed. When the protector is closed, the contact pressure is significant so as to create a solid electrical contact. In the event that the protector fails to open at the time of a severe fault, fuses are present as a final safety precaution. Current transformers for operating the relays are located on each phase of the main bus bars, above the disconnect links. The mechanism is mechanically trip free. The mechanism will not close if it receives a trip instruction at any point in the closing cycle. A shunt trip device, designed to trip at very low voltages when necessary retains the latch. The breaker unit includes accelerating springs so that the breaker contacts may be opened quickly.

### B. 313NP Ratings

Network protectors are furnished in current ratings from 800 to 3500 amperes inclusive. The ampere rating stamped on the nameplate states the maximum current the protector will carry continuously. The most common voltage ratings are 125/216 (phase to ground/phase to phase) and 277/480, 3 phase, 4-wire wye.

Network Protector Amperes	Interrupting Rating Amperes	Suggested Transformer KVA	
		125/216V	277/480V
800	30,000	225	500
1200	30,000	300	750
1600	30,000	500	1000
1875	30,000	500	1000
2000	60,000	500	1000
2500	60,000	600	1,250
3000	60,000	750	1,750
3500	60,000	1,000	2,000

### C. 313NP Housings

All Network Protector housings are designed to allow the mechanism to be rolled out on rails for easy maintenance. The mechanism is able to roll out to the point that it can be vertically lifted out of the housing. The 313NP is available with transformer mounted or wall mounted housings. Each type of housing is available as a submersible or ventilated unit. Many

different types of terminals are available. The type of terminals is tailored to each customer's needs. The submersible housing is manufactured from copper bearing steel. The hinges for the door can be placed on either side of the protector so that the door may swing in either direction. The external operating handle can be mounted on either side of the housing. The handle can be locked in three different positions – "Closed," "Automatic" and "Open." The locking mechanism for the handle consists of a locking block. The locking block is placed inside the handle. This prevents the plunger from being depressed thus preventing the handle from moving (see Diagram 1). Alternatively, a small stainless steel block can be bolted to the handle position support plate. This restricts the handle to the "Open" and "Automatic" positions, thus preventing the mechanism from being closed.

The door contains a window so that the fuses, operations counter and position indicator can be inspected without opening the protector's door. The protector is arranged so that it can be rolled out of its housing far enough to permit lifting the rollout unit vertically and removing it. The non-submersible, ventilated enclosure has its hinges on the right-hand side of the unit with the operating handle mounted on the left.

Diagram 1 – Handle Mechanism

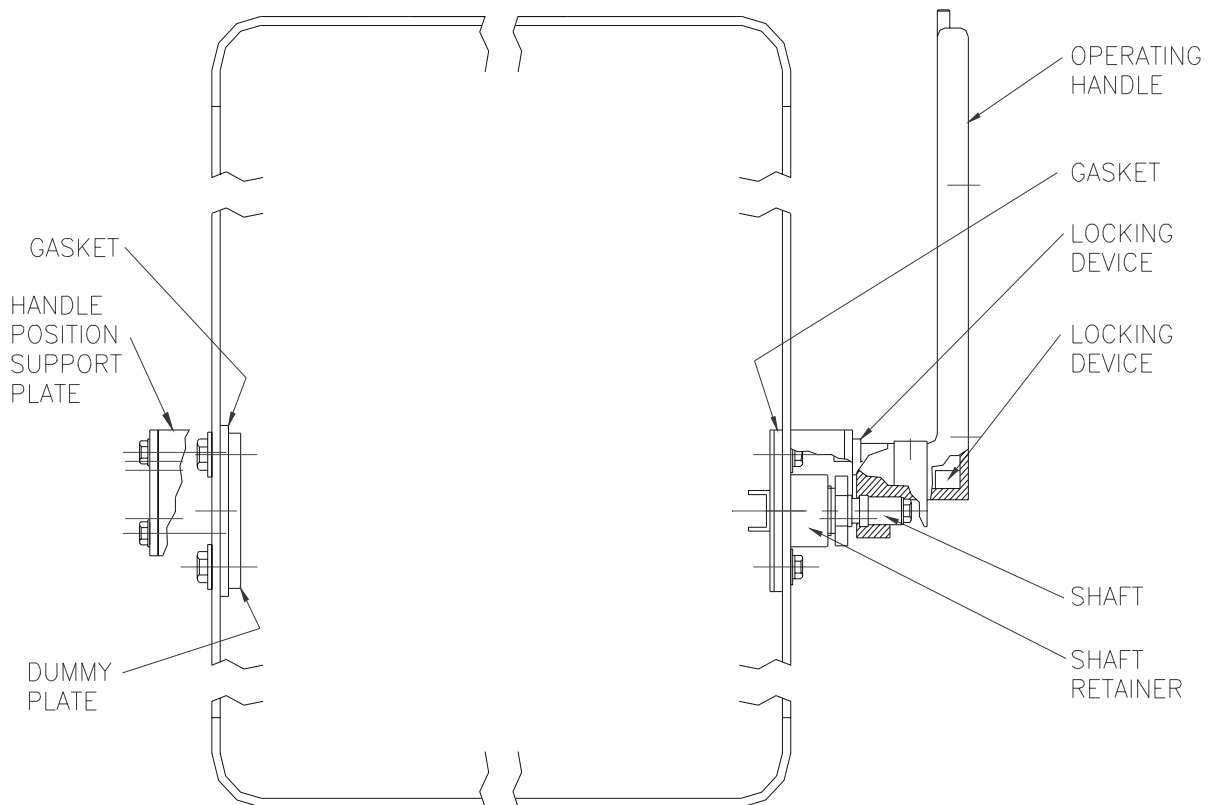

#### **D. The 313NP Mechanism**

All protectors rated between 800 and 1875 amperes have identical mechanisms and relay panels. The only differences are the size of the fuses and the winding ratios of the current transformers. All protectors rated between 2000 and 3500 amperes also have similar mechanisms. The vast majority of parts are common to all current ratings, which reduces the quantity of spare parts the user must retain.

The protector can be rolled out of its housing as described above. The removal of the fuses at the top of the mechanism and the disconnecting links at the bottom isolates the protector from both the primary and secondary sides so that the unit can be tested or have maintenance performed.

## II. INSTALLATION

### A. Receipt Of The 313NP

The 313NP Network Protector should be removed from its packaging in a careful manner such that no parts are damaged. The protector should be immediately inspected to ensure that no damage has occurred during shipment. If the unit has been damaged, the common carrier should be contacted immediately. Any dust that has accumulated during shipment should be removed from the unit. All 313NP protectors should be stored on their backs, or on their feet in a clean, dry location. Submersible units should be stored with their doors sealed.

All 313NP protectors are equipped with holes for lifting the unit into place. The lifting eyes are welded to each side of the housing, near the top. A nylon sling should be used to lift the protector so not to scratch the housing. The sling should be used in conjunction with a spreader so that the cable terminals are not damaged. For a submersible housing, care should be taken to ensure that the door is supported before it is opened with the protector mechanism rolled out. The feet of the protector cannot support the weight of both the door and the mechanism in the rolled out position.

#### 313NP Weight Chart

<b>Mechanism Only</b>	<b>Pounds</b>
800 – 1875 Amperes	400
2000 – 3500 Amperes	600
<b>Housings Only</b>	
Submersible 800 – 1875 Amperes	700
Submersible 2000 – 3500 Amperes	1800
Non-Submersible 800 – 1875 Amperes	500
Non-Submersible 2000 – 3000 Amperes	700
Non-Submersible 3500 Amperes	900

### B. Preliminary Testing

The 313NP protector should be tested before it is installed on a network system. The protector should be firmly mounted and secured. Before connecting the protector to a network system, the fuses and disconnect links should be removed to ensure the isolating of the protector during installation.

**Caution: Before the network protector is operated in any way, the user should ensure that the red bolt that secures the mechanism to the main panel is tight. Failure to tighten this bolt securely will result in a loss of contact pressure, which will cause the protector to overheat.**

The first preliminary test is to ensure that the manual handle is able to move to the "Closed", "Open", and "Automatic" positions. The handle is moved by pressing the plunger and rotating the handle. Each of the three positions is marked on the handle position indicator, which is part of the handle assembly. The handle should be able to be moved to any of the positions regardless of whether the protector is energized and whatever the initial position of the unit. When the handle is moved to the "Closed" position, the breaker should close far enough so that the main closing toggle is over center. This can be tested by slowly moving the handle to the "Closed" position. Before the handle reaches the closed position, an audible click should signal that the main closing toggle has moved over center. Similarly, when the handle is moved from the "Closed" to the "Open" position, a loud click should emerge from the protector before the handle locks in the "Open" position.

### **C. Mounting the 313NP – Mechanical Connection to Transformer**

#### **1. Wall Mounted Protectors**

Wall mounted network protectors should be secured, either directly to a solid wall or to a steel framework that is secured to a solid wall, with four 1/2 bolts for non-submersible or four 3/4 inch bolts for submersible protectors. Enough space should be allocated for the input and output cable connections as well as for opening the door of the protector. The unit should be mounted as close to vertical as possible.

#### **2. Transformer Mounted Protectors**

Before mounting the protector to the transformer the operator should ensure that the transformer is not energized. The housing for the transformer mounted submersible protector is attached to the network transformer at two points, at the low voltage throat and by means of pads located near the bottom of the protector. Richards will supply the hardware for connecting the protector to the transformer. The protector housing should first be supported on the transformer throat using two dowel pins. The pins are located on the transformer and line up with holes at the back of the protector housing. After the pins are in place on the housing, the back of the housing should be bolted to the transformer throat using the bolts provided. When the housing to throat connection is secure, the bottom of the housing is connected to the bottom of the transformer using the mounting brackets provided.

### **D. Mounting the 313NP – Testing and Electrical Connection to Transformer**

When the housing has been secured to the transformer, the housing bus bars should be connected to the transformer outlet bushings on the transformer throat using a flexible connector designed to join the threaded stud emerging from the throat area to the housing bus bars. The mechanism is then ready to be installed in the housing. In order to install the mechanism, the handle must be locked in the open position. Then the mechanism is placed on the housing rails. Before closing the protector into a network, every mechanism should be opened and closed at least five times under control of the ETI MNPR™ (See the wiring diagrams located at the end of this manual). The operator should ensure that the relay

is programmed to the desired specifications. The appropriate voltage for conducting automatic tests should then be applied across the protector using a three-phase test set. If the ETI MNPR™ is not fully operational, the protector may still be operated by applying rated voltage across the outside poles of the circuit breaker and then issuing TRIP and CLOSE commands through the ETI MNPR™ Field Programmer (See Field Programmer Manual). The trip-free action of the mechanism may be tried by immediately tripping the protector after the circuit breaker arcing contacts have touched, during a closing cycle. Once the mechanism has been tested and displays the desired performance, it is ready to be connected to the transformer. The mechanism should be rolled into the housing. The bottom of the housing bus bar should then be connected to the bottom of mechanism using the disconnect links provided. When the mechanism has been installed the fuses are then bolted into place.

### **E. Energizing the Feeder**

Once the protector is mechanically and electrically connected to the transformer and the mechanism has been tested, the main cables leading to the secondary network should be connected to the protector terminals. A connection should then be made between the protector housing and ground. The protector should still be physically locked open using the handle and a locking block. The primary feeder is now ready to be energized. Once it is energized, a suitable voltmeter should be used to measure the voltage differential and phase relations across the protector. If the phase relations are proper and the transformer voltage is higher than the network voltage by the proper amount, the handle should be moved to the automatic position, which should close the protector.

### **F. Checking a Submersible Housing for Water-Tightness**

Although every 313NP Submersible Housing is tested for water-tightness at the factory, the user may wish to retest once the protector is installed. With the protector closed and operating properly, the housing door should be closed and tightened to the case. The seals on the gasket can then be tested by attaching a pressure gauge together with bottled nitrogen to the sampling valve and placing six psi pressure into the housing. Leaks can be then be detected placing soapy water over the gasket seal and checking for air bubbles.

### III.313NP DESIGN

#### A. The 313NP Circuit Breaker

The circuit breaker on the 313NP consists of three independent bus bars (each representing a phase) mounted on an insulating panel along with control wiring.

##### 1. 313NP Units Up To 1875 Amperes

Conductors attached to the insulating panel carry current through the circuit. A knuckle joint holds a frame containing flexible laminated sections of conductor. This joint brings the flexible conductors into and out of contact with the solid conductors on the panel, thus closing and tripping the circuit. When the protector closes, the mechanism closes the joint and holds the frame in place. When a trip instruction is received, the operating mechanism ceases to hold the frame in place. Springs at the upper end of the conductor and springs on the frame then flex the knuckle joint and accelerate the frame away from the stationary contacts. This action breaks the circuit. The flexible conductor on each phase has three parallel sections. The middle section is slightly longer than the outside two. This longer middle section is designed to break contact after the other two sections. The middle section contains the arcing contact, which is controlled by springs such that it is the last point to break from the stationary contact. This arcing contact is designed to absorb all damage to the contact surface that may occur from an arc caused by the interruption of large currents. See Diagrams 2, 3 and 4 on page 8. After a severe current interruption, the protector should be checked carefully and contact maintenance given if necessary.

The 313NP uses a splitter type arc chute. The arc chute is bolted to the arcing contact. The arc chute contains a series of temperature resistant fiberglass and steel plates located in a chamber, which draw the arc upward and lengthen it. The splitter plates cause the arc to split into many arcs once it has entered the chamber. The “stretching out” and continuous cooling of the arc enables the arc chamber to extinguish the arc at the first zero current. The arcing chambers are the same for all rating of protectors. The splitter type of arc chute has interrupt ratings of 30,000 and 60,000 amperes at 600 volts for the 800-1875 and 2000-3500 ampere protectors respectively.

The top end of each circuit breaker bus bars is connected to the top protector terminal by means of a fuse or, a solid link, if there is external fusing. At the lower end of each bus bar there is a copper link making the connection to the lower terminals. The fuses serve the added purpose of breaking the circuit in case the protector fails to open at the time of a primary fault, or if the voltage at the protector is reduced practically to zero by a short between the protector and the transformer. Note, however, that the ETI MNPR™ will trip the protector on voltage as low as 7.5% of the network voltage on any single phase.

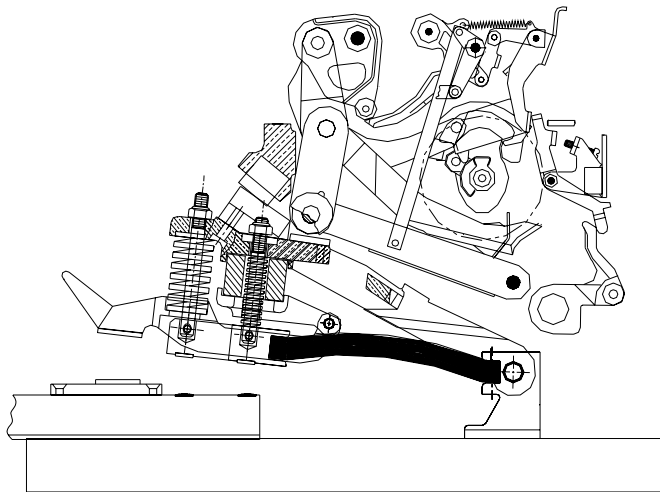

DIAG. 4 PROTECTOR TRIPPED FREE

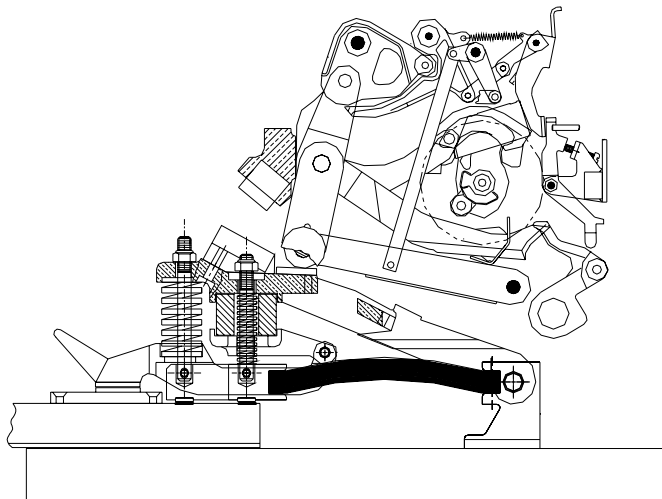

DIAG. 3 PROTECTOR CLOSED

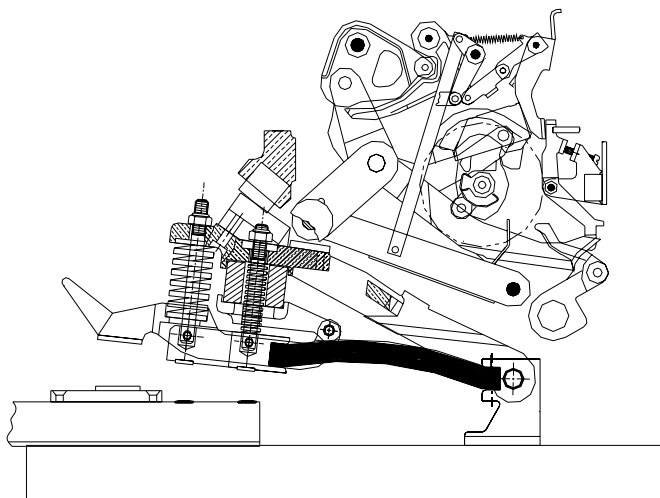

DIAG. 2 PROTECTOR OPEN

Current transformers on each bus bar work in conjunction with the ETI MNPR™ to trip the protector on reverse current. The ETI MNPR™ is adapted for use on protectors with any current rating, since each current rating has its own appropriate set of current transformers.

The primary and secondary contacts of the circuit breaker are made of a weld-resisting alloy. The arcing contacts described above, part shortly after the secondary contacts have opened. The secondary contacts part after the primary contacts. The primary and secondary contacts are protected from arcing by the arcing contacts, and damage to the main contacts is reduced. See Diagram 5 on page 10.

The control wiring is located behind the breaker panel so that it is isolated from the main conducting parts. A grounding stud for the relay is located directly to the rear of the hand-operated shaft at the right edge of the panel. On submersible unit, this stud is automatically connected to the submersible housing when the unit is bolted into the housing. In open type protectors, it is necessary, when installing the protector, to connect this stud to the neutral of the network system.

Fuses at the top of each bus bar, (either internal copper or external silver sand) and disconnecting links at the bottom of each bus bar allow the protector to be disconnected from energized lines. In order to isolate the protector for tests or repairs, both the fuses and the disconnecting links should be removed. If the mounting bolts are then removed, the mechanism can be rolled out on its rails.

## 2. 313NP Units From 2000 to 3500 Amperes

For 313NPs with larger current ratings, the stationary conductor consists of a tubular copper bus mounted vertically on the insulating panel. See Diagram 6 on page 11. The squares are open at each end to facilitate cooling by convection. The larger units replace the smaller unit's flexible conductors with six parallel copper blades per phase. The blades are arranged on each phase as three sets of two. Each blade is hinged at the bottom, and each has jaws at the top, which engage the stationary bus. The construction is similar to a knife switch. The contact points (i.e. the hinged bottom and the jaws at the top) are silver-plated to preserve conductivity. A through bolt and Belleville springs apply pressure to hold the contacts in place. Adjusting the washers can change the quantity of pressure. The stationary contact is also silver-plated at the point of contact. It is tapered to facilitate engagement with the blades.

The top of the moving blade, where it meets the stationary conductor, has a raised, silver-plated, serrated section, which provides a set of multiple line contacts parallel to the direction of motion.

As was the case with the smaller units, when the protector trips, the center pair of blades is designed to break contact only after the outer two pairs. This center pair contains the arcing contacts that are the last point to break contact, and therefore, absorb the arc.

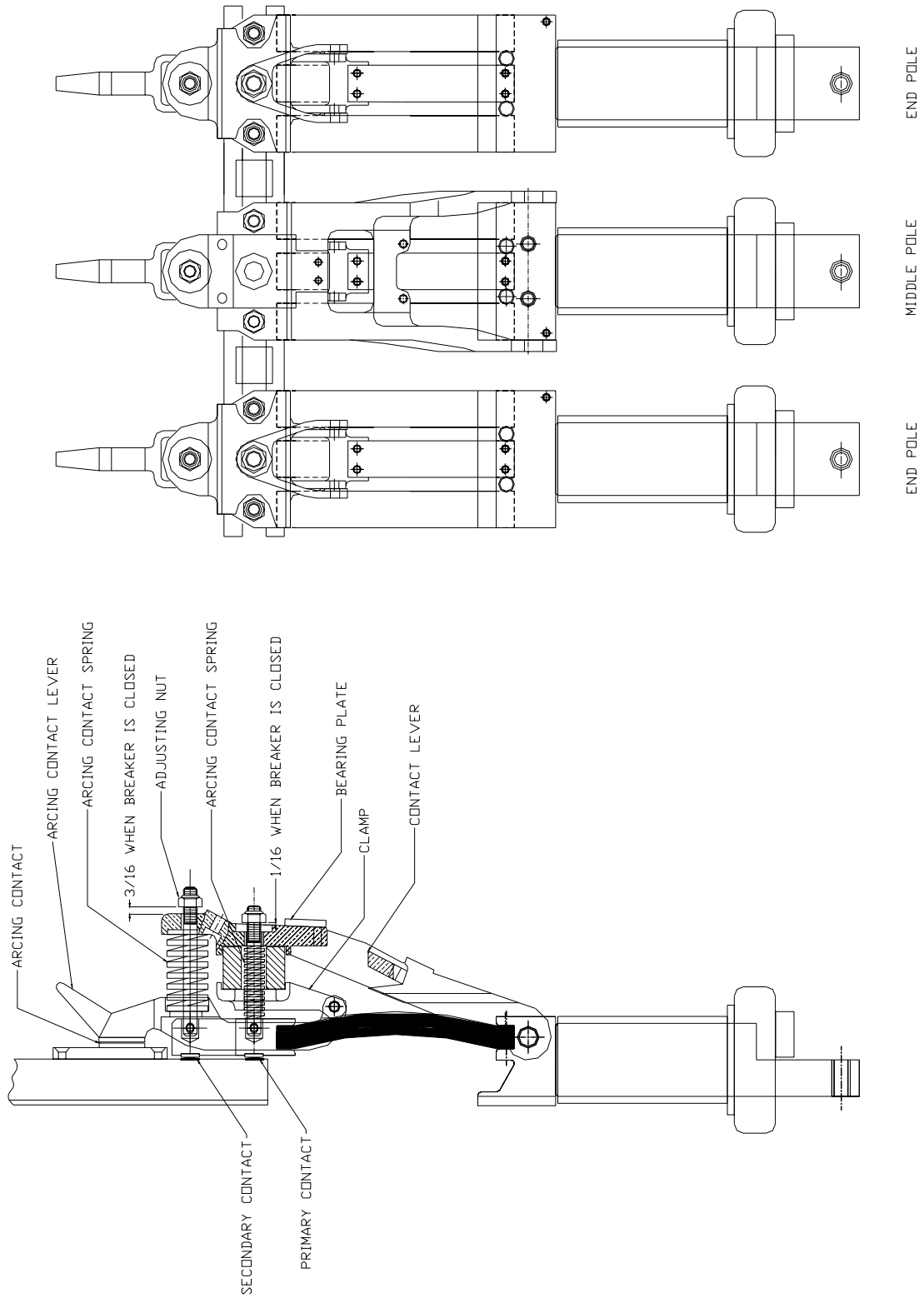

DIAGRAM 5 - CONTACTS, SMALL 313NP UNITS

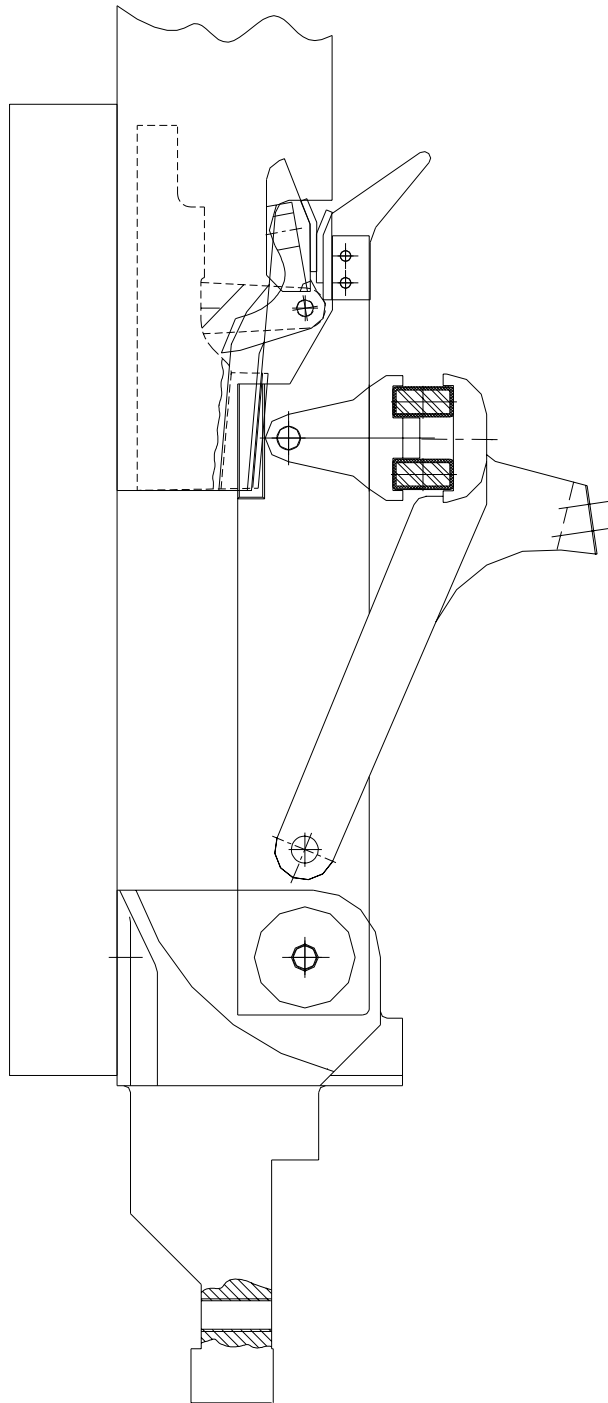

DIAGRAM 6 - CONTACT, LARGE 313NP UNITS

The blades are connected to a crossbar that is propelled by the operating mechanism. The design of the blade contacts makes it unnecessary to hold the contacts in place with pressure. The contact pressure is maintained by the Belleville springs. Therefore, the springs need only be powerful enough to overcome the friction associated with the physical connection between the contacts.

The relatively weak accelerating springs on the crossbar cannot prevent the blades from rebounding when the protector opens on a severe fault. A shock absorbing assembly is located on each side of the circuit breaker to act as a stop for the moving contact assembly and limit rebound.

## **B. The 313NP Mechanism**

The operating mechanism, auxiliary switch, relays, and other devices for the 313NP are assembled together at the front of the protector. This assembly is hinged at the right side and may be released and swung out by releasing two bolts. The first bolt is at the left of the mechanism frame and the second is the red bolt located above and to the right of the MNPR™.

**Caution: The bolt on the mechanism must be securely fastened before any attempt is made to close the protector either manually or electrically. The bolt is painted red and a warning plate on the mechanism signals the requirement that it be secure.**

There is no physical connection holding the mechanism to the circuit breaker. Therefore, a red fiberglass barrier, located in front of the red bolt, prevents the bolt from being withdrawn unless the protector has been tripped.

When the 313NP is operating automatically, a motor closes the circuit and a shunt trip coil trips it. Both the motor and the shunt trip coil are operated automatically by the ETI MNPR™. The closing motor always rotates in the same direction. When the motor circuit is energized the motor rotates a worm gear which in turn rotates a crank which carries the closing roller. When the motor starts to rotate, the closing roller drives the toggle links into alignment. Only the middle and left toggle links move, however, because the right link is held in place by a latch. Before the middle link has aligned itself with the stationary link, but after the middle and left links have passed over center, the closing roller disengages the closing lever. This places a large amount of pressure on the main contacts and the toggle that closes them. The breaker would quickly be forced open but for the latch. The latch in turn is held closed by a small latch toggle, which automatically resets by passing over center when the latch roller is in its lowest position.

A drum switch mounted on the crank of the motor closing mechanism de-energizes the motor when the crank reaches a position approximately 30 degrees beyond the vertical position. When the crank has reached this position, the toggle is already safely in the latched position. One pole of the auxiliary switch is connected in parallel with the drum switch just mentioned.

When the protector is tripped, this pole of the auxiliary switch makes contact. During the next protector closing operation the pole completes the motor circuit until the drum switch makes contact. This auxiliary contact opens before the mechanism closes and the motor is de-energized by the drum switch after the mechanism has closed. The closing crank drifts approximately 45 degrees beyond the point of motor cut-off. The exact stopping position of this crank is unimportant.

The three links in the main toggle have their centerlines placed so that the ends of the middle link move in opposite directions. During an opening cycle, the end links turn clockwise and the middle link turns counter-clockwise with references to their shafts as seen from the side. See Diagram 2. After tripping electrically, the links carry the latch roller back to the reset position. This allows the latch to snap into place using the helical spring supported between the latch and latch toggle.

Diagram 4 shows the position of the mechanism when the protector is opened during a closing cycle (tripped free). Note that there is no way to hold the mechanism in this position.

When the relay mechanism is swung out, mechanical connection between operating mechanism and circuit breaker ceases automatically. Since the mechanism operates the breaker simply by pressing on the movable contact frame or by releasing the pressure, it is not necessary to uncouple any parts when separating the operating mechanism from the breaker.

### **C. The Operating Handle**

At the lower end of the circuit breaker there is a shaft running cross-wise to the protector through the stationary portion of the mechanism frame. This shaft is arranged on submersible protectors to mate with a shaft through either the right or left side of the submersible housing. On open type unit the handle is attached to the left end of this shaft. The handle and shaft combination has three significant positions; “Automatic”, “Open”, and “Closed”. A lever at the shaft engages with a lever of the mechanism toggle so that the movement of the handle from the “Automatic” to the “Closed” position will push the mechanism toggle to the “Closed” position. A safety interlock prevents the mechanism assembly from being released and swung aside unless the handle and shaft are in the “Open” position.

In the open position, a second lever at the center of the shaft engages with a portion of the tripping mechanism in such a manner that the protector is tripped when the handle is moved to the “Open” position. The shaft also actuates a small drum switch at its left end in such a manner that the closing circuit of the motor is opened when the handle is in the “Open” or “Closed” positions, thereby preventing the mechanism from closing electrically when the handle is in these positions. In the closed position of the handle, the protector is able to trip-free from the mechanism, but the protector cannot then re-close automatically until the handle has been restored to the “Automatic” position.

#### **D. The Relay Panel and Auxiliaries**

The ETI MNPR™ and the auxiliary switches for controlling the operation of the protector are mounted on the same hinged assembly as the operating mechanism. The relay plugs into the front of the panel so that no adjustment need be made to the permanent wiring when installing or removing the MNPR™. The necessary wiring for the relay and the auxiliary switches comes across the hinge point of the assembly. This allows free movement of the panel on its hinges without putting any stress on the conductors.

A rotary control switch is used as the main auxiliary switch. Eight circuits are provided for, although they are not all used in the standard wiring arrangement. Contacts are made and opened by metal segments rotated between stationary fingers. The switch contacts are controlled through a mechanical connection with the operating mechanism.

Two auxiliary switch contacts are brought out from the interior of the protector by a disconnect device located on the upper left side of the main panel. These contacts may be used for an interlock, remote position indication, or supervisory system.

#### **E. The Closing Motor**

The closing motor is a single-phase commutator type vertical shaft motor with ball bearings. A single reduction of speed between motor and closing crank is made by worm gear coupled directly to the shaft of the motor, and a worm wheel mounted on the same shaft as the closing crank. Since the service does not require operation of the closing mechanism for any extended period of time, the motor is wound to develop an exceptionally high torque for its size. If operated too frequently during testing (more than twenty consecutive operations) the windings may over-heat. The motor is designed to close the protector at 73% of the motor's rated voltage.

#### **F. The Shunt Trip Assembly**

The shunt trip assembly unit, comprising the trip magnet with its coil, is mounted on a frame that also carries a trip lever, adjusting screw, and coil circuit contacts. The trip magnet is of the solenoid and plunger type with both a stationary and a movable core. Adjustment of the screw fixes the position of the trip lever, which acts also as a stop for the latch toggle. Final adjustment of the screw is made when the unit is in place on the mechanism.

The shunt trip coil is designed to pick up positively at 7.5% of normal voltage. Normally any voltage high enough to pick up the movable core of the trip magnet is sufficient to drive the latch toggle over center and trip the breaker. The shunt trip lever extends to the front of the mechanism frame forming a manual tripping lever. Pressure on this part trips the breaker.

A tripping cycle consists of the following sequence of operations:

1. The MNPR™ closes its tripping contacts (due to system conditions prevailing),

thereby closing the circuit through the shunt trip coil.

2. The opening of the circuit breaker returns the auxiliary switches to their original position, thereby opening the circuit of the shunt trip coil and closing the circuit of the motor control relay, in preparation for the next closing operation.

## **G. Motor Circuit Control**

The motor circuit is controlled by an auxiliary relay, which, in turn is controlled by the ETI MNPR™, and also by the cutoff switch of the mechanism. A signal from the MNPR™ energizes the coil of the auxiliary relay, which then closes its contacts. The closing of these contacts serves to energize the circuit of the motor. When the drum switch on the crank makes contact, it seals the relay in the energized position independent of the MNPR™ contacts. The motor then closes the protector, and after the mechanism latches, the cutoff switch is opened, which de-energizes the auxiliary relay. To prevent attempting to close the protector at voltages below the minimum motor closing voltage, auxiliary relay is designed to pick up at 80% of nominal.

A closing cycle consists of the following sequence of operation:

1. The MNPR™ contacts close, thereby completing the circuit to the coil of the control relay.
2. The control relay energizes its armature, thereby closing its contacts.
3. The motor, being energized by the relay, then rotates the closing crank to a point where the associated drum switch closes its contacts, thereby electrically sealing the relay closed independently of the MNPR™ contacts.
4. As the motor mechanism passes into the latched position, the drum switch opens the circuit of the control relay operating coil, and the auxiliary switch closes the circuit of the shunt trip coil. The closing of the shunt trip circuit prepares for the tripping of the circuit breaker at some future time.
5. The opening of the relay opens the circuit of the motor, thereby removing it from the line.

## **H. Position Indicator and Operations Counter**

The "Open" or "Closed" status of the breaker is identified by a position indicator that gives a mechanical light indication. The words "Open" and "Closed" on a semaphore flag give the position indication. One word or the other is visible from the front of the protector depending on the breaker position. An optional colored lamp is available in conjunction with the semaphore flag. An operations counter is mounted at the front of the protector where it is visible through the window in the enclosure.

## IV.313NP HOUSINGS

### A. Submersible Housings

The housing for the submersible protector is fabricated from copper bearing steel. The entire housing is protected by several coats of high-grade epoxy paint that minimize corrosion in service. The door can be hinged on either side. The housing is made watertight by a Nitrile/PVC gasket that is placed between the housing and the door. The contact surface of the gasket is coated with a zinc oxide paste so that the gasket does not stick to the housing.

The protector rests in its housing on stationary rails, which are welded to the frame of the housing. Movable rails are connected to the stationary rails. These movable rails can be extended outward to allow the unit to be rolled out of the housing.

Tightening all door bolts until they push up against the stops seals the housing. Loosening all of the bolts can open the door. The hinge bolts are loosened until the bolts come against the stops. Then the bolts on the opening side are loosened until they are completely disengaged from the housing blocks. Springs on the hinge bolts keep the hinged side of the door positioned correctly when the door is opened.

The door has a window to allow inspection of the fuses, the position indicator and the operation counter. The window is made from tempered glass and is surrounded by gaskets to keep the housing watertight. An additional window is available to view the MNPR™.

While normally located on the left, the external handle may be placed on the right side of the housing if necessary. An auxiliary shaft mounted in the housing connects the operating handle to the shaft on the protector.

A packing gland tightened by means of a spanner nut provides a watertight seal between the housing and the handle shaft. The spanner nut is held in place by a locking clip. If the hand operating packing gland leaks, the locking clip must be removed, the spanner nut tightened until a watertight seal is obtained. The locking clip should then be replaced

If the housing must be moved through tight quarters, the operating handle may be removed so that the housing is made narrower. This is accomplished by removing the clamping bolt. The handle has a locking flange to allow the protector to be locked in any of the three positions. The operating handle is interlocked so that the mechanism cannot be rolled into the housing unless the protector is open and the handle is in the “Open” position.

The 313NP housing contains the mounting bosses, the rollout rails, the lifting lugs, the entrance bushings, the hinge details for the door, the external operating handle and the provisions for mounting the housing, either on a transformer, or on a wall. Transformer mounted housings have an opening in the back of the housing for mounting directly on to the low voltage throat of the transformer, and pads on the bottom rear of the housing to provide additional support for the protector. All transformer mounted units have a throat opening and

bolt pattern as per IEEE Std C57.12.40-1990. Bus bars mounted in the housing connect the bottom of the protector to the transformer copper.

Different types of terminals are available for connecting the unit to a network. These include flat spade and threaded stud (with a porcelain insulator), and silicone rubber insulated disconnect terminals. The disconnect terminal offers the advantage of a submersible installation with little or no taping.

Steel feet, attached to the bottom of the housing, permit standing the protector in the vertical position before mounting. The door should not be opened when the protector is standing on its feet lacking other support.

## **B. Ventilated Housings**

A ventilated enclosure is used at dry locations, free of flooding. Instead of keeping the mechanism dry, the main function of the ventilated enclosure is to prevent accidental contact with energized parts, and to keep foreign objects from falling into the mechanism. The door is hinged on the right side, and is closed through the use of fasteners. Bolts are not necessary because there is no need for a watertight seal. The fasteners provide easy access to the interior of the protector. The door has a window for inspection of fuses, the position indicator and the operations counter. The ventilated housing is made of sheet steel. As with the submersible unit, it can be mounted directly on the low voltage throat of the transformer, or can be mounted separately on a wall.

The operating handle can be located on either of the housing side, near the bottom. The handle can be locked in any of the three positions (there are almost no occasions where the protector should be locked in the "Closed" position). The handle is mounted on the mechanism and must be removed before the mechanism can be rolled out of the ventilated housing. As with the submersible unit, the mechanism cannot be fully rolled into the housing unless the handle is in the open position.

Like the submersible unit, the mechanism rests in the housing on a stationary track. Movable tracks are fastened to the stationary track. The movable tracks allow the mechanism to be rolled out of the housing.

## V. MAINTENANCE

313NP protectors should be inspected at least once per year. The inspection should consist of both a mechanical checkup followed by a test of the electrical operations of the protector.

**Caution: Before making any inspection of the protector or the relays, it is crucial to isolate the unit from both the transformer and the network. Isolation is accomplished by locking the protector in the open position using the handle and the locking block. The fuses should then be removed, isolating the unit from the network, as well as the disconnect links, which isolates the unit from the transformer. Before performing any work, an appropriate voltmeter, or continuity meter should be used to ensure that the unit is not energized.**

### A. Mechanical Inspection

#### 1. The Circuit Breaker Unit

The following regular maintenance should be performed:

- a. All electrical connections should be tightened.
- b. All springs should be properly placed and in working order.
- c. All nuts, pins, cotters, and screws should be properly placed and tightened.
- d. All current carrying elements should be checked for damage due to overheating.
- e. All contacts should be cleaned and checked to see that they form good electrical connections.
- f. On a small unit, the arcing contacts should make contact before the secondary contacts. The secondary contacts should make contact before the primary contacts. On a large unit, the arcing contacts should make contact before the main blades.
- g. All fiberglass barriers should be checked to ensure that they are not broken.
- h. All connections on the terminal blocks should be checked and tightened.

#### 2. Relay and Mechanism Frame

The following regular maintenance should be performed:

- a. **The red bolt MUST be tightened before operating the protector.**
- b. All electrical connections should be tightened.
- c. All springs should be properly placed and in working order.
- d. All nuts, pins, cotters, and screws should be properly placed and tightened.
- e. The bumper should be properly placed and should extend above its socket.
- f. The clearance between the roller mechanism and the bearing plate should be checked with the unit open to ensure that it is a minimum of 1/64 inch.
- g. All fiberglass barriers should be checked to ensure that they are not broken.

- h. The motor control relay and cutoff switch should be checked to ensure a good electrical contact.
3. The Housing

The following regular maintenance should be performed:

- a. All electrical connections should be tightened.
- b. The fuses disconnect links and terminals should be examined for damage associated with overheating.
- c. The housing itself should be checked for corrosion.
- d. All fiberglass barriers should be examined to make sure that none are broken.
- e. The housing itself should be checked to ensure that it is watertight.
- f. The handle should be checked to ensure that it operates properly. The contacts should complete their movement (opening and closing) before the handle locks into the open or closed position.

## **B. Contacts 800 through 1875 Amperes**

### 1. Flexible Contacts

The laminated flexible contacts need only be inspected for mechanical damage. Replacement will be required only in rare instances.

### 2. Main Contacts

The primary and secondary contacts should be kept clean and free from mechanical damage. The silver plated sections must be kept smooth and flat. If the silver parts are damaged, a fine file can be used to smooth them. If the protected has tripped on a severe short, the contact surfaces should be checked and repaired if necessary.

### 3. Arcing Contacts and Arc Chutes

The arcing contacts should not require replacement throughout the life of the unit. The arcing contacts should make and break contact when the main contacts are approximately 3/16 of an inch open. See Diagram 5. The distance can be adjusted with the contact adjusting nuts. These nuts produce the initial deflection of the spring behind the alloy contacts. After a severe fault, the arcing contacts should be checked to ensure they are in working order.

The arc chute requires no maintenance other than inspection to ensure that the path between the splitter plates is kept clear.

## **C. Contacts 2000 through 3500 Amperes**

### **1. Blades**

The 2000 through 3500 ampere units have hinged blade contacts similar to a knife switch. The contact surfaces on the blades should not require maintenance. The stationary contact's surfaces should be kept smooth and flat. Damage should be smoothed out with a fine file. The factory applies a coating of graphite grease to the blades to reduce friction. The factory coating should last the life of the protector. However, if the grease needs to be replaced, a suspension of graphite in petroleum jelly should be used. It is important that the grease be applied sparingly because it is conductive and could cause problems if splattered on other parts of the contact assembly.

### **2. Arcing Contacts**

After a severe fault, the arcing contacts should be checked for damage. The arc chutes should be checked to ensure that the path between the plates is kept clear.

## **D. Fuses**

The fuses should be checked to make sure that all contact surfaces are clean and make good electrical connections. All mechanical connections should be tightened. If an internal copper fuse has blown, the deposits must be cleaned from the breaker parts, as they are conductive. Obviously, a blown external silver sand fuse will not leave any deposits on the interior of the unit.

The fuses at the upper end and the line-contact disconnect links at the lower end connect the breaker unit to the protector terminals. The contact surfaces to which these links and fuses bolt must be lined up to ensure a good electrical connection and to prevent stress in the fuses. The fuse mounting surfaces should be parallel and separated by not more than 1/32 inch.

## **E. Fiberglass Barriers**

Red fiberglass barriers are located at various points throughout the protector. The main barriers segregate the individual phases near the fuses, the arc chutes and the disconnect links. These barriers can be removed if necessary by removing the bolts that hold them in place. The protector should not be energized while these barriers are removed. Other barriers are located throughout the protector to protect maintenance workers and fragile protector parts.

## **F. Current Transformers**

The current transformers are located on each phase on the bus bars above the disconnect links. The sole purpose of the current transformers is to provide the relay with an appropriate signal. The secondary current of these current transformers at normal full load of the protector is 5 amperes. It is essential that the current transformers be connected with proper

polarity in all cases. The current transformers carry a mark on one face adjacent to one of the secondary terminals. This mark indicates the proper polarity for both the primary and the secondary sides of the current transformer. The current transformers should always be mounted with the mark facing up. One side of the current transformer secondary is connected to the copper conductor on which the transformer is mounted, and this portion of the circuit then becomes common to the current and potential circuit of the master relay.

## **G. Miscellaneous**

### **1. Motor Control Relay Switch**

When the handle is placed in the automatic position, a switch located on the handle shaft near the lower left corner of the main panel should close. This switch is part of the motor control relay circuit and should be inspected occasionally to ensure that its contacts are clean and in working order.

### **2. Dashpot**

On those protectors where an air dashpot is used to decelerate the moving contact assembly during the opening stroke of the breaker, the dashpot should be inspected annually to ensure that it is in proper working order. The dashpot may need to be cleaned and oiled.

### **3. Motor Brushes**

The motor brushes should be inspected annually to ensure they are in good condition. They should not require frequent maintenance.

### **4. Shunt Trip and Motor Closing Units**

The shunt trip unit and motor closing units are connected similarly. Either can be disconnected by removing the two hexagon head bolts that project below the frame of the units. The units can be withdrawn downward and the electrical connections will sever automatically at the double pole butt-contact connector. The trip lever on the shunt trip unit assembly should be seated beneath the trip lever on the mechanism assembly. This is facilitated by first swinging out the relay panel assembly and depressing the manual trip lever in the front of the mechanism.

When replacing the closing motor, care should be taken to ensure that the coupling found at the end of the motor shaft is rotated so that it will enter the worm shaft. The motor should not be rotated manually in the opposite direction from its automatic movement. Reverse rotation of the motor will jam the mechanism and shatter the key that attaches the worm gear to the worm gear shaft.

## 5. Motor Cutoff Switch

The motor cut-off switch can be found inside the motor mechanism mounted on the worm gear shaft. The switch should be inspected periodically to ensure that its contacts are in working order. If this switch does not maintain a good electrical contact, the protector may only partially close and then overheat due to the lack of contact pressure.

## 6. Auxiliary Switch

The auxiliary switch located on the upper right of the relay panel requires no maintenance. The normal action of the switch keeps its contacts clean.

## 7. Auxiliary Relay

The auxiliary motor control relay should be inspected to ensure that the contact surfaces maintain a good electrical contact.

# **H. Submersible Housing**

The outer surface of the housing should be kept in good condition, free of corrosion. Any damage to the paint should be repaired with a rust resistant paint.

## 1. Leak Testing

Submersible housings should be checked for leaks periodically (once per year). In locations where submersion is frequent, inspection should occur more frequently.

Six to eight weeks after installing a unit or after changing a gasket, the bolts on the gasket joint should be tightened and the housing should be tested for leaks. Further tightening of gasket joints should be unnecessary.

Every 313NP protector is supplied with a #302 valve manufactured by Cable Associates, a division of Richards Mfg. Co. Alternatively, a Belknap #994 valve is available. Either valve fits easily onto the pipe threads at the test point located on top of the housing. In the factory, a 24-hour leakage test is performed on every housing. In the field, the watertight seal can be tested by pumping 2-3 psi of either air or bottled nitrogen into the sealed protector through the test valve. A leak detector (usually soap-water) can be brushed onto the sealed surfaces, and the surfaces checked for leaks. Alternatively, the unit can be stored under pressure for an extended period of time, and then checked for a reduction in pressure using the test valve. Note, however, that operating the protector under load for 24-hours will add approximately an additional three pounds of pressure to the housing. Pressures greater than 7 psi should not be allowed to remain in the protector.

## 2. Gaskets

### a. Materials

The main door gasket on the 313NP is made of Nitrile/PVC. The gaskets for the terminals, side glass assemblies, handle and dummy plate are made of Armstrong-710 or a competitive material.

Zinc oxide grease is used between the gasket surface on the housing and the Nitrile/PVC gasket to prevent sticking. Westinghouse gasket cement is used for all sealing gaskets (non-compression gaskets).

### b. Replacement of Door Gasket

To replace the door gasket, the following steps should be followed:

- i. Before removing the gasket it is necessary to remove the door from the housing. Referring to Diagram 7 on page 26, the cotter pins "G" and the stop nuts "N" should be removed from the hinge bolts "H." The hinge bolts should be loosened first, about  $\frac{1}{2}$ ", so when the bolts "M" on the opening side are loosened, all gasket pressure is released. The removal of all bolts will then release the door from the housing.
- ii. The old gasket should be removed and the steel bearing surfaces on the door and housing should be cleaned.
- iii. The gasket length should be cut a few inches longer than will be needed. The end should be cut smooth and straight. One end should be inserted near the center of one of the long sides of the door and the gasket should be inserted around the periphery of the door, either manually or with the aid of a tool such as a hammer with a plastic end or wide nosed pliers. The gasket should be inserted so that in its final position it is free from twists or waves. The gasket should not be inserted by stretching. Stretching the gasket will cause uneven gasket pressure. The gasket should be trimmed so that it fits exactly in the perimeter of the door. The meeting point should then be sealed with rubber cement.
- iv. The outside of the gasket should be covered with zinc oxide paste to keep it from sticking to the housing.
- v. The door on the housing should then be replaced and bolts "H" and "M" should be tightened until the housing is watertight. All bolts should be tightened an equivalent amount to obtain a uniform deflection of the gasket. A torque of 300 pound inches on the bolts should be sufficient to obtain a watertight seal on the door gasket.

vi. On the hinged and opening sides of the housing, stop nuts "I, O" should be tightened against the support block on the housing. Stop nuts "N" should then be assembled on the hinge bolts "H" allowing space between the nuts and block so that there is enough bolt movement available to release the gasket pressure on the hinged side.

vii. The cotter pins on hinge bolts "H" should then be replaced

c. Adjustment of Door Gasket

When a door needs additional tightening to make it watertight, stop nuts "N" and "I" should be loosened and instruction v) and vi) above should be followed.

3. Centering the Door on the Housing

To center the door on the housing, proceed as follows:

- a. The guide brackets should be set in the housing so that they will support the door in its correct vertical position.
- b. The door should be slid horizontally until it is in the correct position.
- c. On the hinged side of the housing the sub-assemblies, each consisting of the hinge bolt "H", the hinge block "D", the spring "K" and the two stop nuts "I" should be threaded into support blocks "P" on the housing until lower pivot pins "A" can be inserted. The upper and lower pivot pins "A" must have the correct number of spacing washers "C" between nut "F" and hinge block "D" to support the door in its correct vertical position. The pivot pins "A" should then be clamped in place by tightening nuts "F." With all pivot pin assemblies on the hinged side in place and securely tightened, the door may now be swung several times to see that its location is correct on the housing. If necessary, the pivot pins "A" can be moved horizontally by sliding these pins in the slot in the hinged bracket "L." The pins can be moved vertically using the spacing washers, "C."
- d. The clamping bolts on the opening side of the housing should now be assembled in a manner similar to the one used on the hinged side. The bolt should be positioned to enter the tapped hole in the housing support block "P" as freely as possible. The bolts may be adjusted vertically using the washers at the lower end of swivel block "D."
- e. The stop nuts should now be set as previously described.
- f. A light coating of grease is recommended on all exterior bolts and pivot points.

#### 4. The Operating Handle

The packing gland for the shaft of the handle may require occasional tightening to keep a watertight seal.

To change the operating handle of the housing from one side to the other proceed as follows:

- a. The bolt that holds the handle to the housing shaft should be removed.
- b. The circuit breaker unit should then be dismantled from the housing and the housing auxiliary shaft removed.
- c. The tongue end of the shaft should be switched from one side of the circuit breaker to the other.
- d. The handle packing gland's parts (the locking piece, gland, bearing, packing, and auxiliary shaft) should be removed from the operating handle side. The dummy plate should be removed from the plug side.
- e. The operating handle details and dummy plate should be switched to the other side of the housing and re-assembled.
- f. The operating handle should be re-attached to the housing.
- g. All gasket and gland connections on the operating handle and dummy side should be checked to ensure that they are watertight.
- h. If the handle is switched after the unit has been in service, the dummy plate and handle gaskets should be changed.

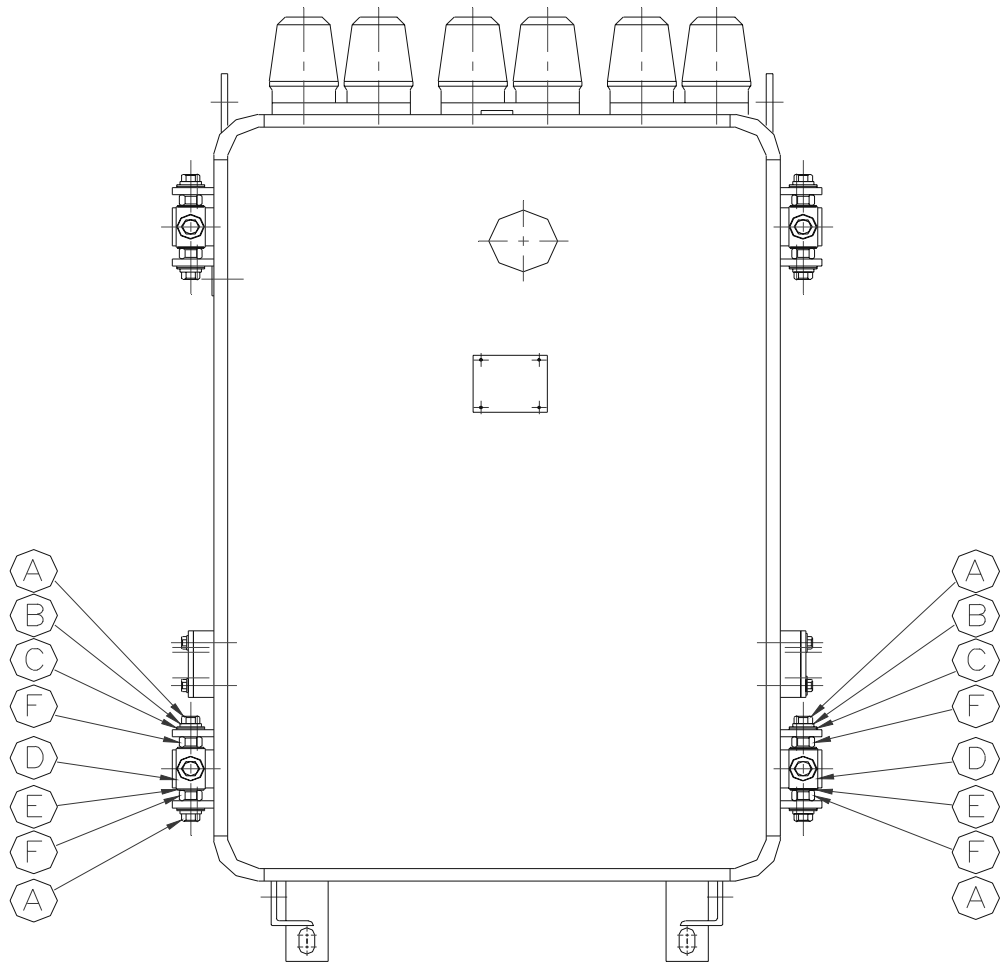
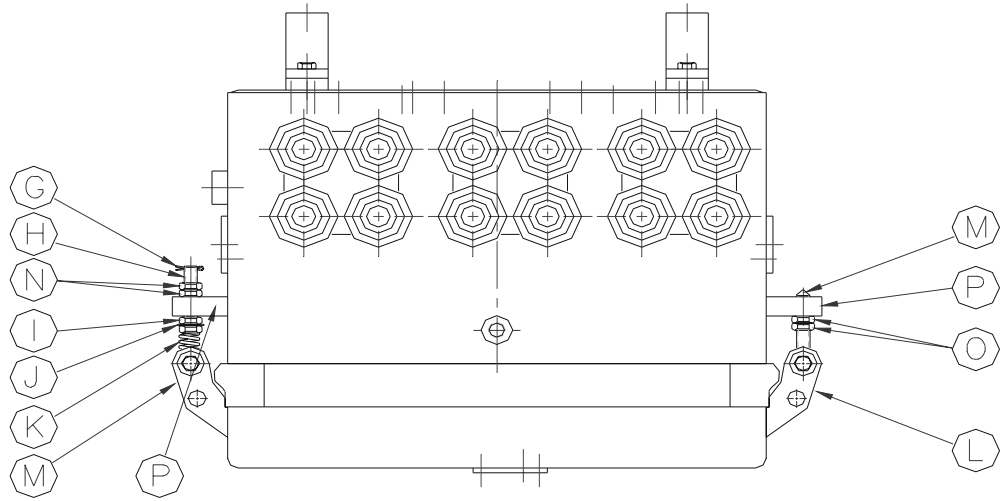

Diagram 7 – Door Hinge Assembly

## **I. Non Submersible Housings**

The only maintenance that is required on a non-submersible housing is periodic inspection of the paint on the housing and inspection of the barriers.

## VI. ADJUSTMENTS

### A. Circuit Breaker, 800 through 1875 Ampere Units

The main contacts of the 313NP should close so that the main contact spring compresses 1/16" and the transfer contact springs compress 3/16" after the contacts first touch. See Diagram 5. If the contact do not meet these specifications the adjusting nuts on the springs should be tuned. These settings are important for there to be the correct contact pressure and to ensure that the main and auxiliary contacts break contact in the same order.

### B. Circuit Breaker, 2000 through 3500 Ampere Units

As illustrated in Diagram 8 on page 29, the larger 313NP protectors have contacts similar to a knife switch. There are three pairs of moving blades for each phase that connect three moving conductors "D" to a stationary conductor "G".

Contact pressure is maintained by Belleville springs, "C". Two Belleville springs are located on either side of each moving blade. The pressure can be adjusted by tuning the nuts and bolts on the blades. A castellated nut is used which can be locked to the bolt or stud with a cotter pin after final adjustments have been made. After the contact have been aligned properly, and have been set at the proper pressure, the stationary and moving conductors "G" and "D" are doweled to the panel to prevent any subsequent movement. In view of this, no adjustment of these conductors should be necessary in the field.

If the contact pressure needs to be set in the field, castings "A" are properly located and securely fastened to the crossbar. Proper location of these castings on the crossbar consists of maintaining the 1/64 to 1/32 dimension between the blades "D" and the casting "A." After this has been done, the contacts should be checked with a .0015 feeler gauge. If this feeler is inserted between the moving and stationary blades at point "F", it must not enter for a length more than 1/2 inch. This still leaves approximately 1 1/2" contact. A slight increase in contact pressure will close this gap when necessary.

Following this, the contact pressure on each individual blade can be adjusted. With 100 amperes d-c on each phase, the resistance between the moving and stationary blades "G-H" should be between 11 and 13 microohms. The continuity in each phase should be checked, after which adjustments can be made on those contacts that show the greatest variation above these limits.

Any necessary adjustments can then be made by loosening or tightening the nuts "B" depending upon whether the drop across the contacts needs to be increased or decreased. The protector should be opened and closed a few times to seat the contacts properly after each contact adjustment and before each continuity reading. Excessive pressure may cause the protector to fail to trip under heavy load conditions.

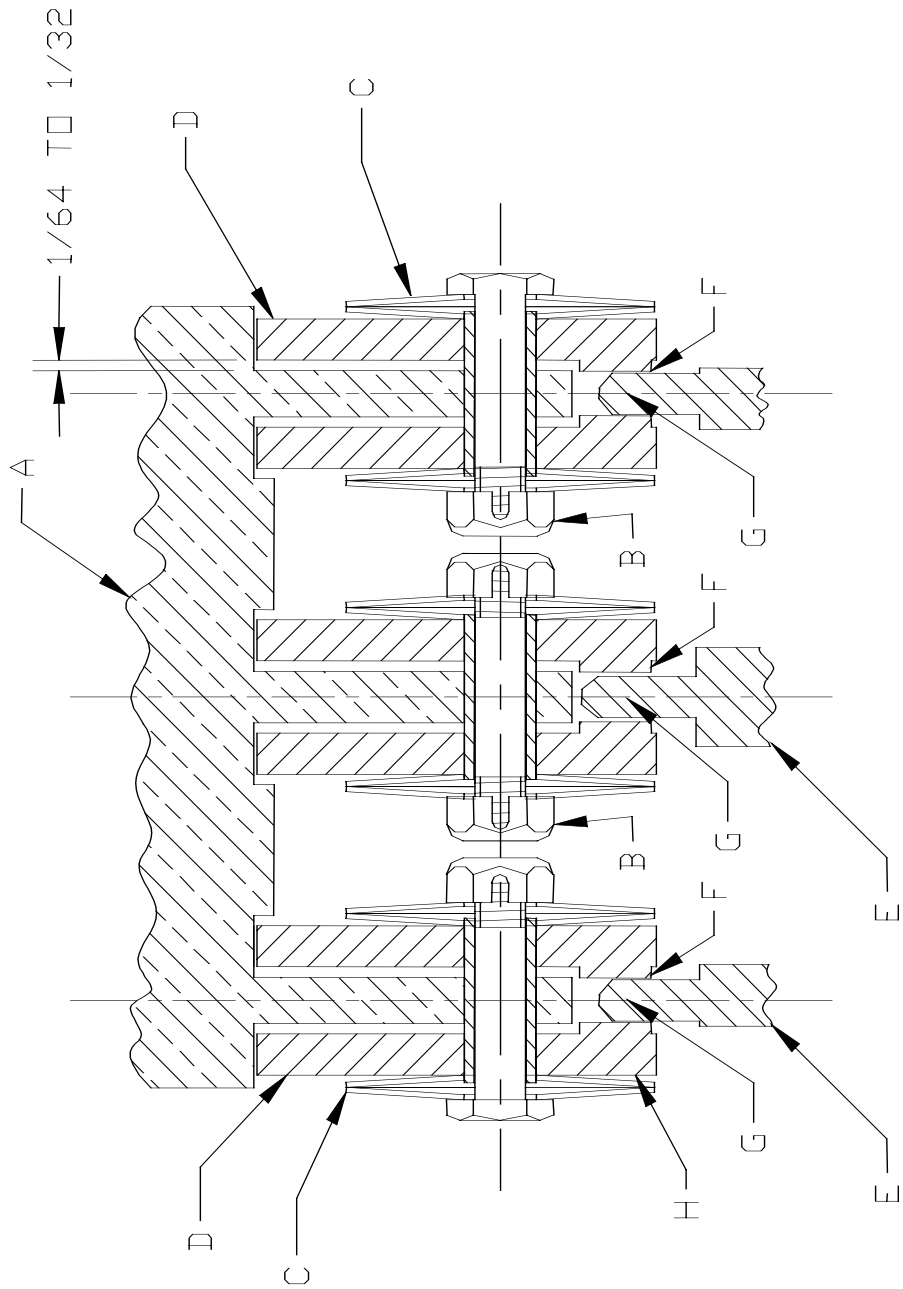

DIAGRAM 8 - CONTACTS, LARGE 313NP UNITS

When all these adjustments have been made, the contact nuts should be locked in place with cotter pins.

The contacts should then be operated manually a number of times to see if they operate properly. Finally, the protector should be operated at the minimum closing voltage of 73% of the rated protector voltage to make sure the motor is strong enough to fully close the contacts, and to check that the shunt trip is strong enough to trip the protector. When the arcing contacts first touch, there should be a minimum  $3/32$ " gap at the main contacts to assure proper protection of the main contacts when interrupting fault currents. When the protector is opened and the mechanism securely fastened to the breaker unit, the arcing contacts should measure to ensure they are a minimum of  $3/4$ " from the stationary contacts. This can be adjusted by tuning the nut on the rod of the dashpot assembly and rotating the piston to the correct position. There must be a minimum  $1/64$ " separation between the mechanism roller and the plate on the crossbar assembly on which the roller bears when closing the protector. When the piston is in the correct position, the nut is tightened against the piston, locking it in place. Two holes in the piston allow it to be held in place while it is locked.

### **C. Adjusting the Operating Mechanism**

Adjustment of the shunt trip adjusting screw fixes the position of the trip lever, which acts as a stop for the latch toggle. Final adjustment of the setscrew is made while the shunt trip is in place on the mechanism. Latch toggle loads, which the trip magnet must overcome when tripping the breaker, are reduced by turning the screw clockwise, or increased by the reverse movement.

In general, a light load is desirable, which means that the screw should be so adjusted as to allow the latch toggle to pass only slightly over center. The adjustment should not be too light, as it may cause the protector trip accidentally from vibrations. Locations that are subject to vibrations require a latch toggle setting farther over center than that required under steadier conditions.

A good adjustment for average conditions can be made by removing the latch spring and setting the latch toggle so that it will just barely hold the breaker closed during a closing operation. When the spring is restored to its position the additional holding-in force that it provides will be sufficient for the majority of cases.

The auxiliary relay mounted on the relay panel should be so adjusted that the armature will be picked up at 80% normal voltage as described in detailed tests of the operating mechanism. This is adjusted by means of the setscrew and lock nut at the top of the relay. Since the operating motor will close the protector at 73% of rated voltage, a pick-up adjustment of 80% of normal voltage on the relay assures that the motor will always receive enough energy to close the breaker.

The operating arm of the operation counter may be adjusted as follows:

The clamping screw in the arm of the counter should be loosened until the arm may be moved on its shaft, but still has sufficient friction to operate the counter. With the clamp screw so set, the arm should be placed in approximately the desired position. The protector should then be operated several times to see if the counter works. If the counter works, the clamping screw should be tightened. If the counter failed, the arm should be shifted slightly and the protector operated again.

#### **D. Adjusting the Housing**

If the door on a submersible housing needs to be adjusted in the field to obtain a watertight seal, a torque of 300 pound-inches applied to each of the clamping and hinge bolts should produce a watertight seal. In case a torque wrench is not available, the stop nuts at all the clamping points should be backed off a uniform amount and the door tightened to the new stop position. This procedure should be done in approximately 1/16" steps.

No adjustments are necessary for a ventilated housing.

